

AKK-04FC.03

KNX Switch Actuator 4-channel, 2 SU MDRC, 16 A, 230 V AC, compact, 70 µF, 10 ECG, Fan coil

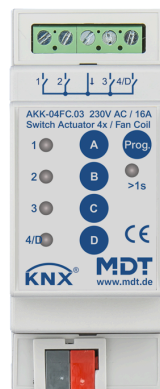

Product description:

The compact MDT Switch Actuator AKK additionally has a "Fan Coil" functionality. This enables the automatic and manual control of ventilators or fan coils with up to 4 steps. The maximum switching capacity is 16 A and 70 µF C-Load

Product functions:

- **Operation mode - Fan coil:**
- Control of 3/4-step ventilators/Fan coil units
- Additional switch output in 3-step operation
- Outputs interlocked against each other (software control)
- Direct operation over three 1 Bit objects or single 1 Bit object (+/-)
- Automatic operation via 1 Byte control value (0-100 %)
- Suitable for 2-pipe/4-pipe systems
- Output object to control heating-/cooling valves
- Day/Night function to limit the ventilation steps at night
- Emergency operation on failure of the control value
- **Operation mode - Switch Actuator:**
- Normally open and normally closed
- Time functions (switch-on / switch-off delay)
- Staircase light function with selectable pre-warning time
- Status feedback for all channels (active/passive)
- Logical functions, 8 scenes per channel
- Central functions and blocking objects for forced operation
- Behaviour on Bus power failure/reset selectable
- Fast application download (long frame support as of ETS 5)

Technical data:

Device	Device type	AKK Switch Actuator	
	Article Number	AKK-04FC.03	
	EAN / GTIN	4251916130220	
	Installation width	2 SU / 36 mm	
	Dimensions (H x W x D)	90 x 36 x 65 mm	
	Weight, gross (incl. packaging)	0.156 kg	
	Protection classification	IP20	
	Installation type	MDRC, DIN rail 35 mm	
	Installation position	any	
	Weight, net	0.137 kg	
	Mechanical manual override	No	
	Performance data	Nominal voltage U_n	230 V AC ^{*1}
		Nominal current I_n (per output)	10 A
Nominal frequency		50/60 Hz	
Relay type		bistable	
Mech. switching frequency		1.000.000	
Capacitive load		70 μ F / 16 A	
Fluorescent lamp load AX		\leq 16 AX	
Power dissipation of the device, typical		\leq 3 W	
Outputs	Number of outputs	4	
Lamp data	Incandescent lamp load	2000 W	
	HV-Halogen lamps	2000 W	
	NV-Halogen lamps	1200 W	
	Fluorescent lamp uncompensated	1800 W	
	Fluorescent lamp parallel compensation	800 W	
	Max. number of ECG	10	
Currents	Inrush current (150 μ s)	300 A	
	Inrush current (600 μ s)	150 A	
	Total current carrying capacity of the actuator	16 A	
KNX	Nominal voltage KNX	30 V DC SELV	
	Voltage range KNX	21 ... 31 V DC SELV	
	Typical power consumption KNX bus	< 0,3 W	
	KNX Medium	TP-256 with long frame support	
	KNX Application	as of ETS 4	

Technical data:

Environmental conditions	Ambient operating temperature	0 ... 45 °C
	Storage	-20 ... +55 °C
	Humidity	< 95 %
	Condensation permissible	No
Connections	Connection type	Screw terminal with slotted head
	Conductor cross section 1 x	0,5 ... 2,5 mm ²
	KNX connection type	KNX terminal
	KNX cable cross section	0.6 ... 0.8 mm, solid conductor

Hinweise

Protection against induced voltage spikes: To protect against voltage spikes when switching off inductive loads, it is recommended to use appropriate protective circuits such as flyback diodes, RC networks, or varistors directly at the actuator output.

*1 Mixed operation of nominal and safety extra low voltage (SELV) within the actuator is not permitted!

Wiring diagram: single channel

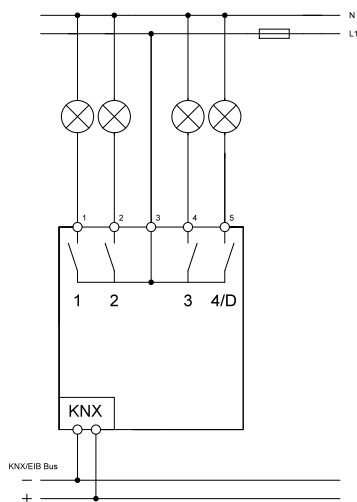

Wiring diagram: Fan / Fan Coil Unit

